



FICHE D'INSTRUCTION TECHNIQUE

N°: V 50 1002

TRACTEUR PNEUMATIQUE VISA TV400 - VISA PNEUMATIC
FITTING TOOL TV400 - TRATTORE PNEUMATICO VISA
TV400 - PISTOLA NEUMÁTICA VISA TV400 -
PNEUMATISCHES MONTAGEWERKZEUG TV400 fÜR VISA -
PNEUMATISCHES MONTAGEWERKZEUG TV400 fÜR VISA

Date : 17/04/2012

Indice : M

INSTRUCTIONS

VISA PNEUMATIC FITTING TOOL (TRACTOR) TV 400



Translation of the original instructions



FICHE D'INSTRUCTION TECHNIQUE

N°: V 50 1002

TRACTEUR PNEUMATIQUE VISA TV400 - VISA PNEUMATIC FITTING TOOL TV400 - TRATTORE PNEUMATICO VISA TV400 - PISTOLA NEUMÁTICA VISA TV400 - PNEUMATISCHES MONTAGEWERKZEUG TV400 FÜR VISA - PNEUMATISCHES MONTAGEWERKZEUG TV400 FÜR VISA

Date : 17/04/2012

Indice : M

1. TECHNICAL DESCRIPTION

1.1. Description

The VISA TV 400 is a pneumatic tool developing 3600 N, consisting of a cylinder on which three types of 360°-rotating nose can be fitted:

- VISA short nose
- VISA long nose
- Band cutter nose

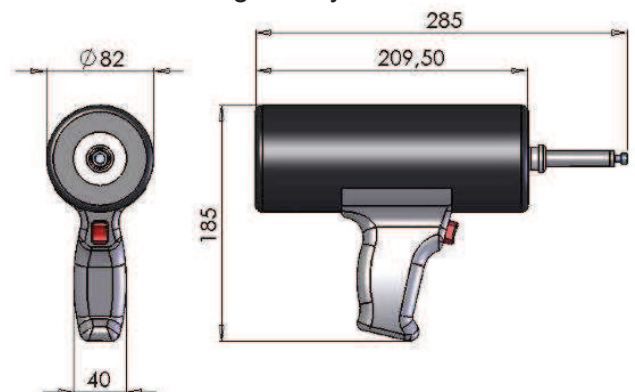

Weight: 1.850 kg

Recommended operating pressure: 5,5 to 6 bar

Noise level: <70 dB(A)

**No element other than the above shall be fitted on the cylinder.
Use of the tool for any other purpose than fitting VISA clamps is forbidden.**

1.2. Operation

Once the clamp is positioned (1), introduce its upper band in the tool's nose (2). The tool's shoe must rest against the clamp's support wedge (3).

Pull the trigger until the shear-pip is shorn (4), release it and remove the tool (5).

Do not apply any stress on the clamp during tightening.

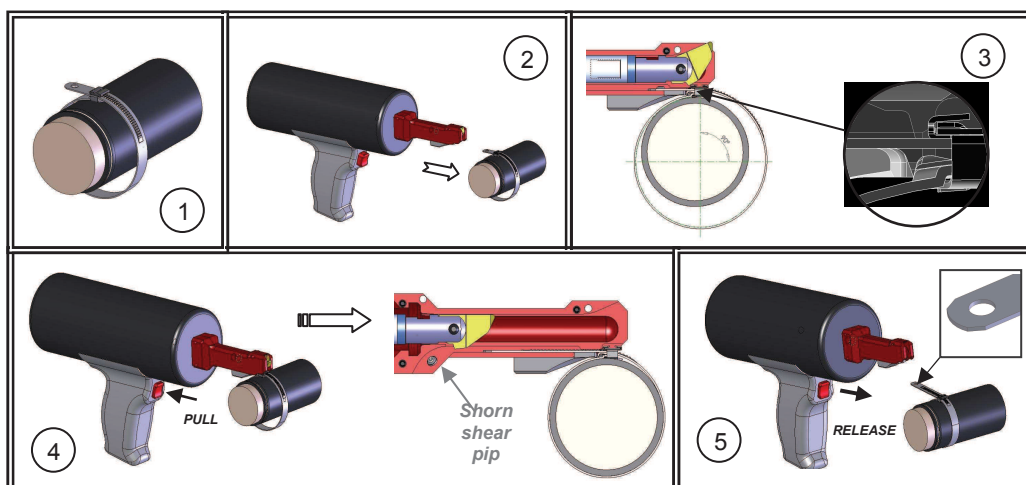



FICHE D'INSTRUCTION TECHNIQUE

N°: V 50 1002

TRACTEUR PNEUMATIQUE VISA TV400 - VISA PNEUMATIC FITTING TOOL TV400 - TRATTORE PNEUMATICO VISA TV400 - PISTOLA NEUMÁTICA VISA TV400 - PNEUMATISCHES MONTAGEWERKZEUG TV400 FÜR VISA - PNEUMATISCHES MONTAGEWERKZEUG TV400 FÜR VISA

Date : 17/04/2012

Indice : M

VISA clamps can be removed with: - a screwdriver
- cutting pliers

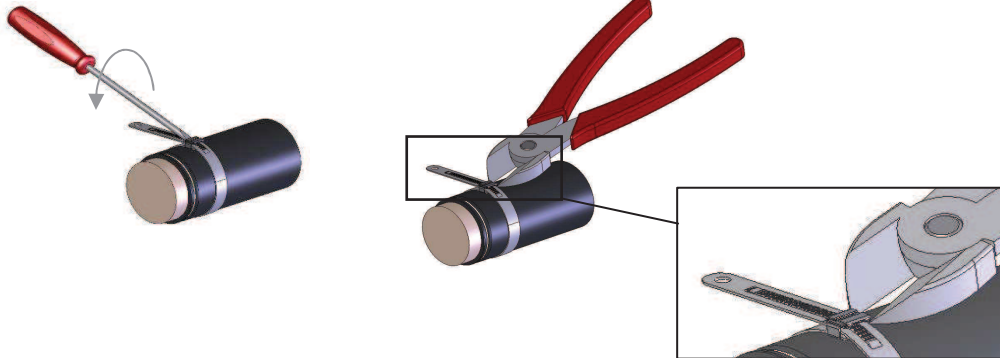

1.3. Precautions for use:

- All tools in operation must be equipped with the deflector (safety).
- Recommended operating pressure: 5.5 to 6 bar
- Use dry, lubricated air.
- Connection thread size: 1/8" BSP (cylindrical coupling with sealing washer).
- Avoid any grease inside the nose.
- Hold the nose properly when tightening the clamp.

Correct position

Wrong position

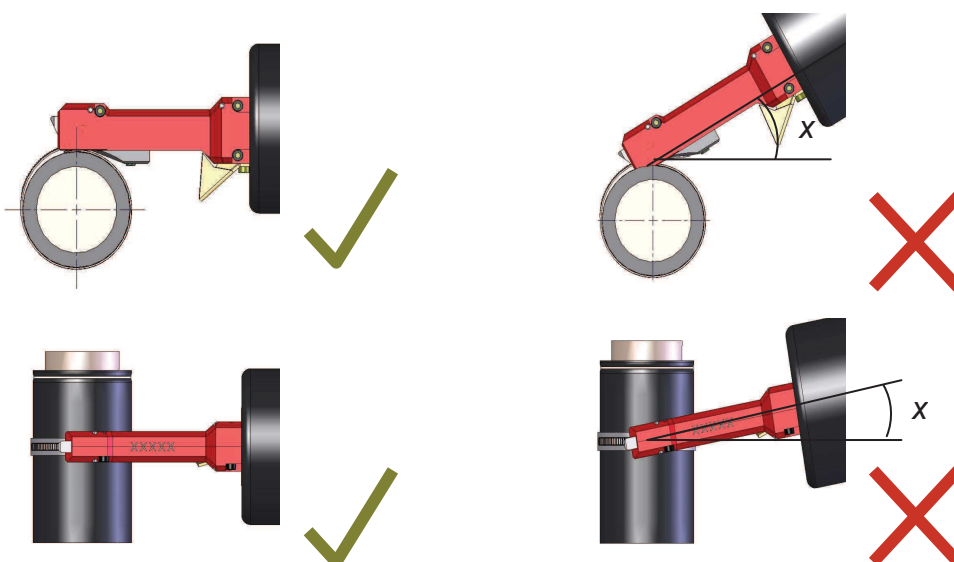

- If fitting is automated, only the tool or the application may be fixed, not both.

Tools must be serviced and maintained according to our specifications and instructions and using our spare parts.

Any modification, displacement of original dimensions or deviation beyond wear values can generate fitting defects.

For any operation other than the above, please refer to CAILLAU.



FICHE D'INSTRUCTION TECHNIQUE

N°: V 50 1002

TRACTEUR PNEUMATIQUE VISA TV400 - VISA PNEUMATIC FITTING TOOL TV400 - TRATTORE PNEUMATICO VISA TV400 - PISTOLA NEUMÁTICA VISA TV400 - PNEUMATISCHES MONTAGEWERKZEUG TV400 FÜR VISA - PNEUMATISCHES MONTAGEWERKZEUG TV400 FÜR VISA

Date : 17/04/2012

Indice : M

1.4. Maintenance:

- Clean the nose once a day with compressed air.
- Check the wear of the shoe (after 60,000 operations)

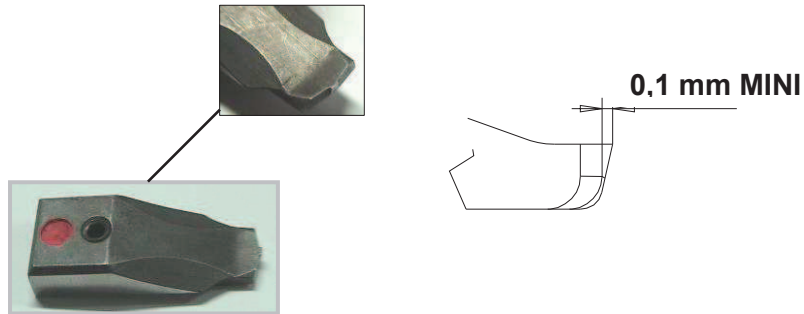

Size of min. 0.1 for the spike at the end of the shoe.

- After 60,000 operations
 - If spike < 0.1 mm
- ⇒ CHANGE THE SHOE

- Check the wear of the cutting bit (after 100,000 operations)

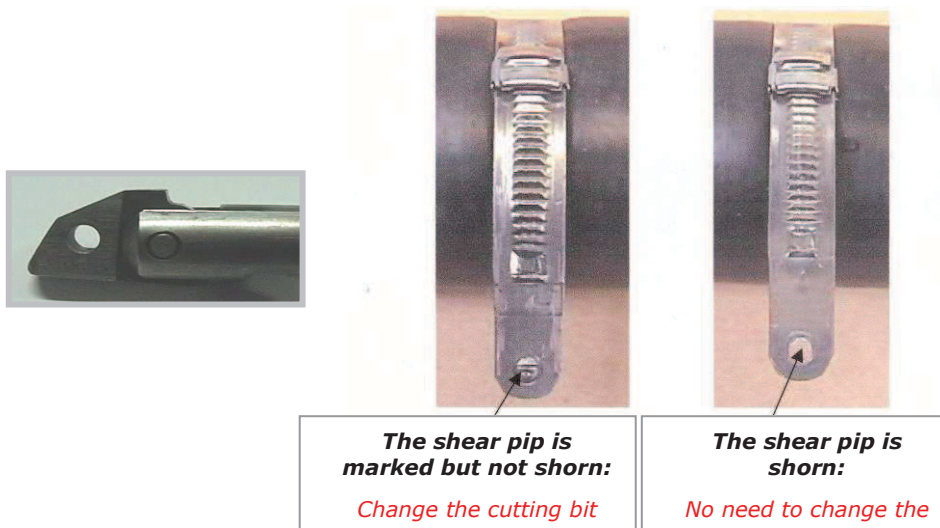



FICHE D'INSTRUCTION TECHNIQUE

N° : V 50 1002

TRACTEUR PNEUMATIQUE VISA TV400 - VISA PNEUMATIC FITTING TOOL TV400 - TRATTORE PNEUMATICO VISA TV400 - PISTOLA NEUMÁTICA VISA TV400 - PNEUMATISCHES MONTAGEWERKZEUG TV400 fÜR VISA – PNEUMATISCHES MONTAGEWERKZEUG TV400 fÜR VISA

Date : 17/04/2012

Indice : M

	<i>Problem</i>	<i>Causes</i>	<i>Solutions</i>
1	<i>The tool does not work.</i>	<i>Lack of compressed air.</i>	<i>Check connection and compressed air supply.</i>
3	<i>Compressed air leaks around the hose connection.</i>	<i>Coupling is loose.</i>	<i>Check hose connection.</i>
6	<i>Compressed air leaks around the control valve.</i>	<i>Control valve or gaskets are worn out.</i>	<i>Change the gaskets or the valve kit.</i>
10	<i>Loss of power</i>	<i>Improper air supply or leaks</i>	<i>Check that pressure complies with the recommendations of the instruction manual and search for leaks.</i>

	FICHE D'INSTRUCTION TECHNIQUE	N° : V 50 1002
	TRACTEUR PNEUMATIQUE VISA TV400 - VISA PNEUMATIC FITTING TOOL TV400 - TRATTORE PNEUMATICO VISA TV400 - PISTOLA NEUMÁTICA VISA TV400 - PNEUMATISCHES MONTAGEWERKZEUG TV400 fÜR VISA – PNEUMATISCHES MONTAGEWERKZEUG TV400 fÜR VISA	Date : 17/04/2012 Indice : M

1.5. Safety instructions

Read this manual before using the tool and follow the operating and safety instructions in order to receive the maximum benefit of the fitting tool you just purchased.

CAILLAU assumes no liability for personal injury or property damage resulting from failure to comply with the safety instructions and rules contained in this manual.

The use of hearing protectors is required.

Before performing any replacement or repair operation or when you are not using the tool, make sure you cut off the compressed air supply, bleed the hose and unplug the unit from the main supply.

Comply with the air pressure recommended in the manual.

Maintenance of the tool must be performed by trained personnel.

CAILLAU declines responsibility in case of:

- Modifications to the original structure of the fitting tool.
- Use of the fitting tool for any application other than that specified in the instruction manual.
- Replacements with components or parts unauthorized by CAILLAU.



According to Directive 89/656/EEC

All rights to this document are reserved.



FICHE D'INSTRUCTION TECHNIQUE

N°: V 50 1002

TRACTEUR PNEUMATIQUE VISA TV400 - VISA PNEUMATIC FITTING TOOL TV400 - TRATTORE PNEUMATICO VISA TV400 - PISTOLA NEUMÁTICA VISA TV400 - PNEUMATISCHES MONTAGEWERKZEUG TV400 FÜR VISA - PNEUMATISCHES MONTAGEWERKZEUG TV400 FÜR VISA

Date : 17/04/2012

Indice : M

2. VISA SHORT NOSE

2.1. Assembly

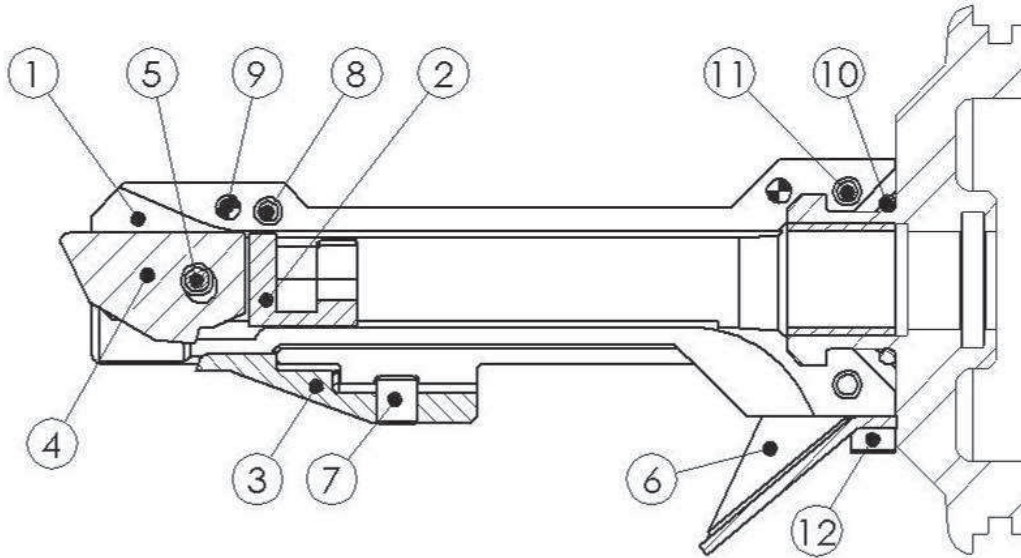

- Grease and fit the O-ring (10).
- Fit the cutting bit + cap (4)+(2+5) assembly onto the cylinder's rod.
- Fit the nose's 2 half-casings (1). The pair must not be separated (part n° straddling the parting line).
- Fit and tighten the 2 M3x16 Allen screws (11) and the M3x8 Allen screw (8).
- Position the shoe (3) and tighten the M5x5 locking screw (7).
- Fit the deflector (6) and tighten the 2 CHC_M3x6 screws (12).
- Check nose rotation: it must rotate 360° but not turn freely.

Nose part n° straddling the 2 half-casings.

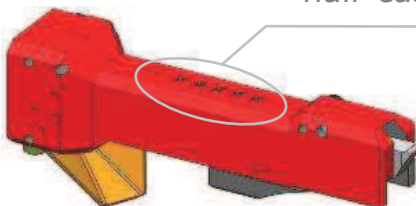



FICHE D'INSTRUCTION TECHNIQUE

N°: V 50 1002

TRACTEUR PNEUMATIQUE VISA TV400 - VISA PNEUMATIC FITTING TOOL TV400 - TRATTORE PNEUMATICO VISA TV400 - PISTOLA NEUMÁTICA VISA TV400 - PNEUMATISCHES MONTAGEWERKZEUG TV400 FÜR VISA - PNEUMATISCHES MONTAGEWERKZEUG TV400 FÜR VISA

Date : 17/04/2012

Indice : M

2.2. Designation of components

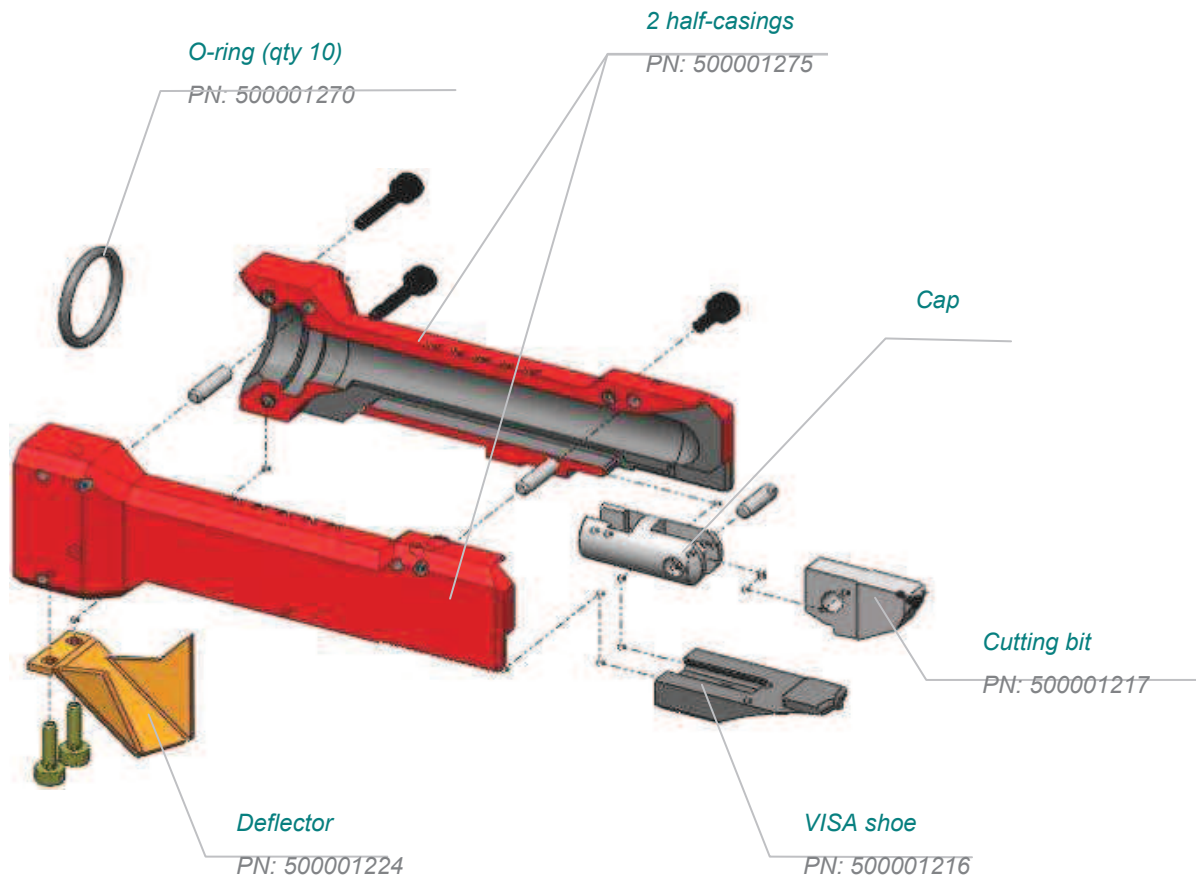

Spare parts for the SHORT NOSE	
Designation	PN
TV400 + equipped VISA short nose	500001200
Equipped VISA short nose	500001226
2 half-casings	500001275
Cutting bit + cap	500001213
O-ring (10 units)	500001270
Cutting bit	500001217
Shoe	500001216
Deflector	500001224



FICHE D'INSTRUCTION TECHNIQUE

N°: V 50 1002

TRACTEUR PNEUMATIQUE VISA TV400 - VISA PNEUMATIC
FITTING TOOL TV400 - TRATTORE PNEUMATICO VISA
TV400 - PISTOLA NEUMÁTICA VISA TV400 -
PNEUMATISCHES MONTAGEWERKZEUG TV400 fÜR VISA -
PNEUMATISCHES MONTAGEWERKZEUG TV400 fÜR VISA

Date : 17/04/2012

Indice : M

3. VISA LONG NOSE

3.1. Assembly

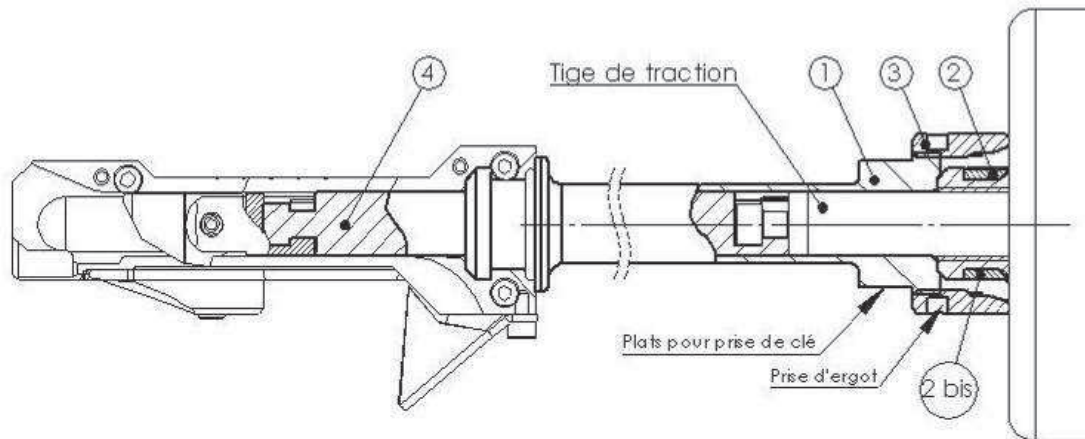

- a- Fit the extension (4) on the rod coupler.
- b- Position the 2 half-shells (2)+(2 bis), (chamfered edges facing the cylinder).
- c- Position the raising block (1).
- d- Firmly tighten the nut (3) using a pin wrench. (The raising block must be immobilised during tightening using the flats).
- e- Fit the nose following the appropriate procedure.



FICHE D'INSTRUCTION TECHNIQUE

N° : V 50 1002

TRACTEUR PNEUMATIQUE VISA TV400 - VISA PNEUMATIC FITTING TOOL TV400 - TRATTORE PNEUMATICO VISA TV400 - PISTOLA NEUMÁTICA VISA TV400 - PNEUMATISCHES MONTAGEWERKZEUG TV400 fÜR VISA - PNEUMATISCHES MONTAGEWERKZEUG TV400 fÜR VISA

Date : 17/04/2012

Indice : M

3.2. Designation of components:

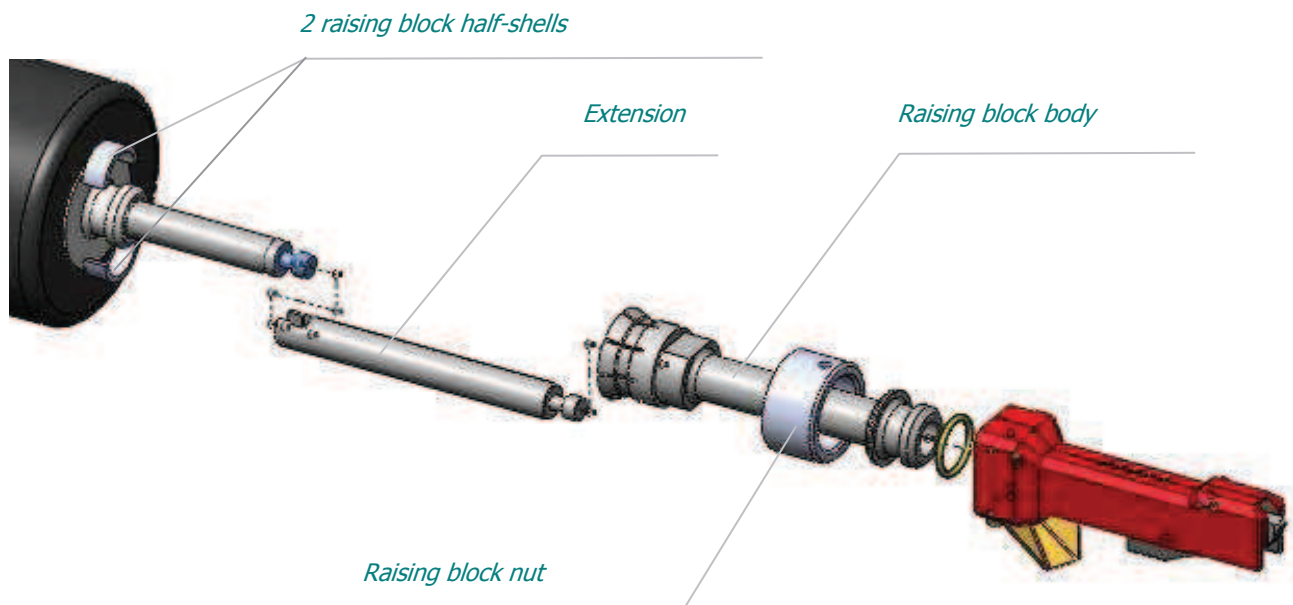

Spare parts for the VISA LONG NOSE	
Designation	PN
TV400 + VISA long nose 173 mm	500001214
Straight raising block, length 73 mm	500001232
TV400 + VISA long nose 245 mm	500001215
VISA long nose 245 mm	500001251
Straight raising block, length 145 mm	500001219
Straight raising block, length 218 mm	500001225



FICHE D'INSTRUCTION TECHNIQUE

N°: V 50 1002

TRACTEUR PNEUMATIQUE VISA TV400 - VISA PNEUMATIC FITTING TOOL TV400 - TRATTORE PNEUMATICO VISA TV400 - PISTOLA NEUMÁTICA VISA TV400 - PNEUMATISCHES MONTAGEWERKZEUG TV400 fÜR VISA - PNEUMATISCHES MONTAGEWERKZEUG TV400 fÜR VISA

Date : 17/04/2012

Indice : M

4. BAND CUTTER NOSE

4.1. Assembly

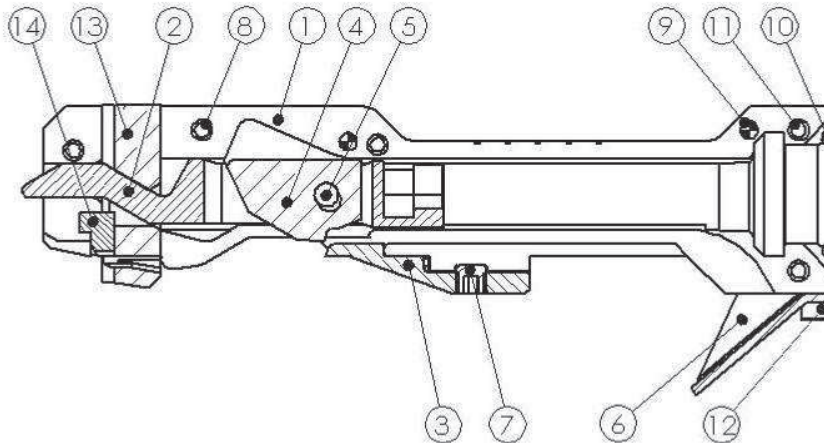

- a- Put the cylinder in vertical position, rod sticking out.
- b- Grease and fit the O-ring (10).
- c- Fit the cap (2) (with cutting bit (4+5)) on the cylinder's rod.
- d- Slip the knife (13) onto the cap (2).
- e- Put the blade (14) on the knife (13).
- f- Fit the first half-casing (1).
- g- Fit the 2nd half-casing (1 bis).
- h- Fit and tighten the 2 M3x16 Allen screws (11) and the 3 M3x8 Allen screws (8).
- i- Fit and screw the deflector (6).
- j- Position the shoe (3) and tighten (avoid excess tightening).
- k- Check nose rotation: it must rotate 360° but not turn freely.

All screws must be fitted using low-strength threadlockers.



FICHE D'INSTRUCTION TECHNIQUE

N°: V 50 1002

TRACTEUR PNEUMATIQUE VISA TV400 - VISA PNEUMATIC FITTING TOOL TV400 - TRATTORE PNEUMATICO VISA TV400 - PISTOLA NEUMÁTICA VISA TV400 - PNEUMATISCHES MONTAGEWERKZEUG TV400 FÜR VISA - PNEUMATISCHES MONTAGEWERKZEUG TV400 FÜR VISA

Date : 17/04/2012

Indice : M

4.2. Designation of components

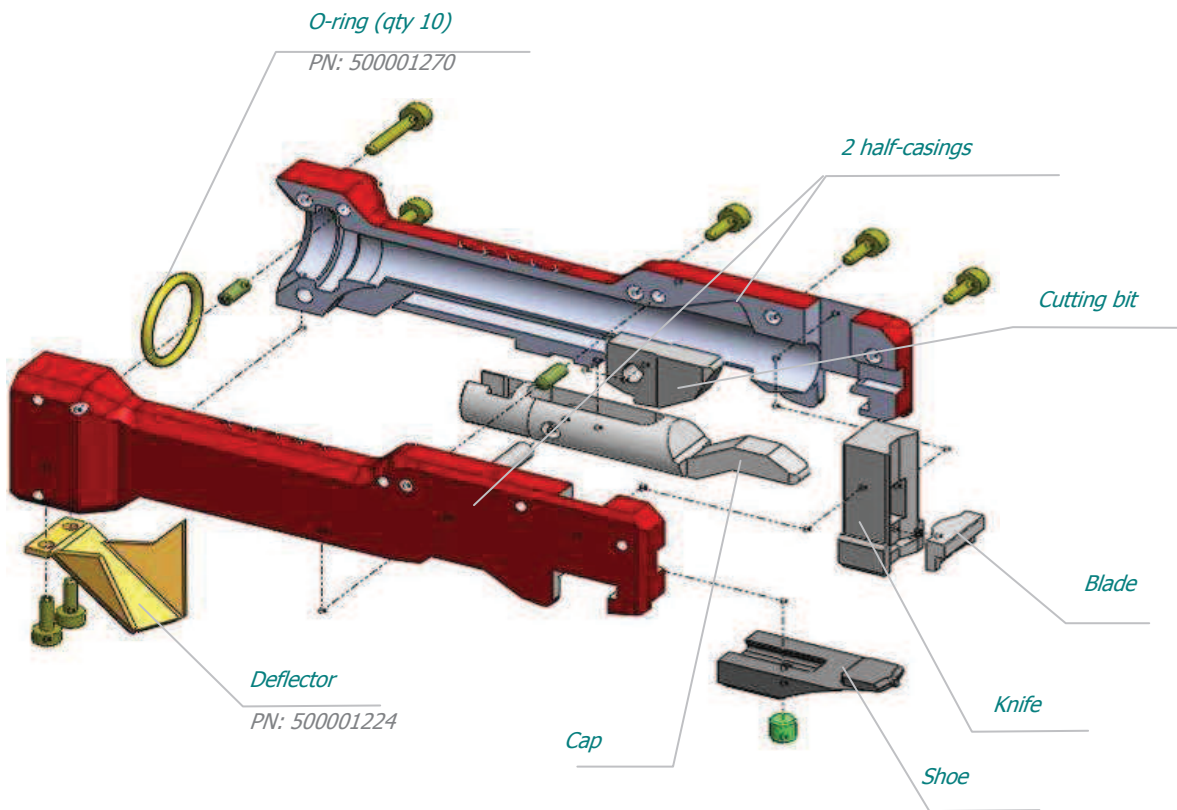

Spare parts for the BAND CUTTER NOSE	
Designation	PN
TV400 + band cutter nose + shoe	500001204
Band cutter nose	500001253
Knife + blade	500001234
Cap + cutting bit	500001236
O-ring (10 units)	500001270
Cutting bit	500001217
Shoe	500001216
Deflector	500001224



FICHE D'INSTRUCTION TECHNIQUE

N°: V 50 1002

TRACTEUR PNEUMATIQUE VISA TV400 - VISA PNEUMATIC FITTING TOOL TV400 - TRATTORE PNEUMATICO VISA TV400 - PISTOLA NEUMÁTICA VISA TV400 - PNEUMATISCHES MONTAGEWERKZEUG TV400 FÜR VISA - PNEUMATISCHES MONTAGEWERKZEUG TV400 FÜR VISA

Date : 17/04/2012

Indice : M

5. OPERATION

1. Tightening the VISA clamp -> Picture 1

- (1) introduce the upper band of the VISA clamp in the nose (shoe side) (3), the support wedge in contact with the shoe.
- (2) Pull the trigger of the TV 400 cylinder until the shear-pip is shorn.
- (3) Release the trigger.
- (4) Remove the tool.

2. Cutting off the excess band -> Picture 2

- (1) Introduce the upper band of the clamp in the nose (knife side) (13).
- (2) Pull the trigger of the TV 400 cylinder until the excess band is cut off.
- (3) Release the trigger.
- (4) Collect the cut-off band.

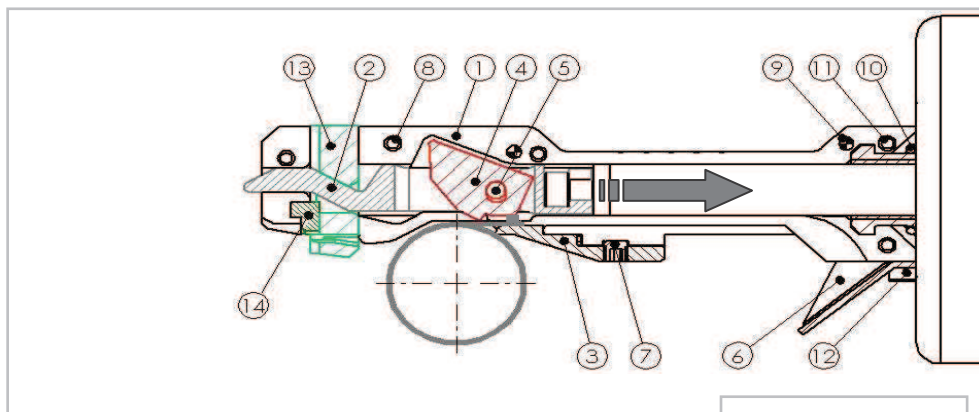

Picture 1

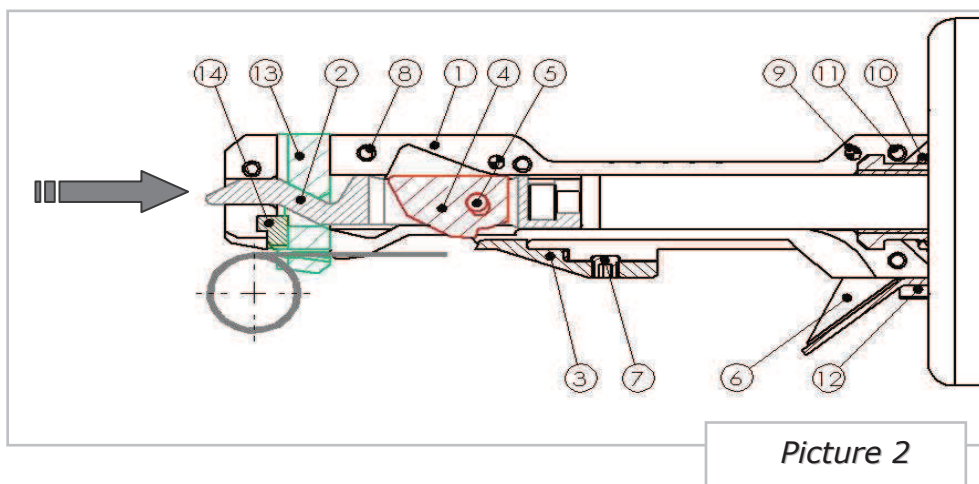

Picture 2



FICHE D'INSTRUCTION TECHNIQUE

N°: V 50 1002

TRACTEUR PNEUMATIQUE VISA TV400 - VISA PNEUMATIC FITTING TOOL TV400 - TRATTORE PNEUMATICO VISA TV400 - PISTOLA NEUMÁTICA VISA TV400 - PNEUMATISCHES MONTAGEWERKZEUG TV400 FÜR VISA - PNEUMATISCHES MONTAGEWERKZEUG TV400 FÜR VISA

Date : 17/04/2012

Indice : M

6. TV 400: OPTIONS & SPARE PARTS

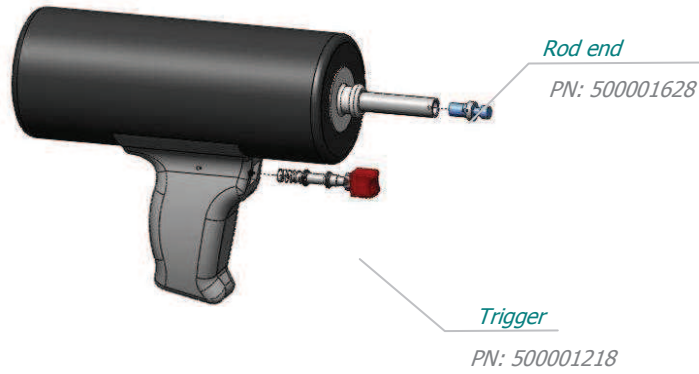

<i>Spare parts for the TV 400</i>	
Designation	PN
TV400	500001212
Trigger	500001218
Valve spool + trigger kit	509001200
Rod end	500001628

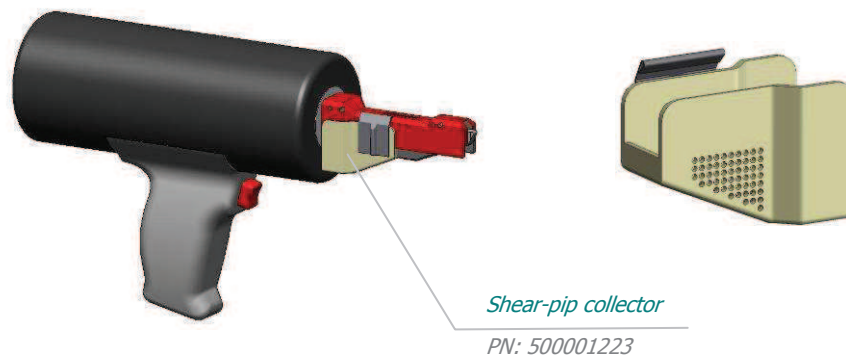

<i>Optional parts for the TV400 + Nose</i>	
Designation	PN
Shear-pip collector	500001223