

OVERVIEW

The Metrix Digital Proximity System (DPS) combines the performance of a fully API 670 compliant eddy-current proximity measurement system with the flexibility of digital configurability. For the first time, users can configure their transducer system in the field using a custom field-generated curve as well as factory pre-configured calibrations for a variety of probe tip diameters, manufacturers, extension cable lengths, target materials, and linear ranges. Refer to page two of this datasheet for additional details on device configurability.



The DPS consists of three elements: a Probe, Extension Cable, and Driver or Transmitter.

MX8030 & MX2030 PROBE SERIES

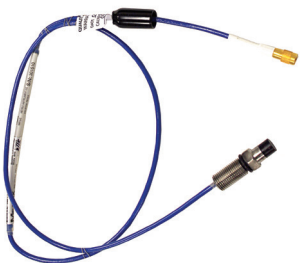

The MX8030 and MX2030 probe series consist of 5mm and 8mm tip diameter probes. The MX8030 comes standard with triaxial cable and VibeLock™5 connectors. The MX2030 comes standard with a coaxial cable and rounded knurled connectors. Both probes offer a full 80 mil (2mm) range, and are designed to offer full API 670 compliance when used with a matching MX8031 or MX2031 extension cable and a MX2033 driver or a MX2034 transmitter.

MX8080 and MX2030 probes are fully interchangeable with Bently Nevada (BN)⁴, 3300 and 3300XL 5mm/8mm probes.

MX8031 & MX2031 EXTENSION CABLES



Available in a variety of lengths and with optional protective cable armor. The MX8031 extension cable comes standard with triaxial cable and VibeLock™5 connector. The MX2031 comes standard with a coaxial cable and rounded knurled connector.

The MX8031 and MX2031 Extension Cables are compatible with both Metrix MX8030 and MX2030 5mm/8mm probes and BN⁴ 3300 and 3300XL 5mm/8mm probes.

PROBE DRIVER OR TRANSMITTER

A probe or transmitter is available, depending on the required signal output format: the MX2033 3-Wire Driver and the MX2034 4-20 mA Transmitter. The models are fully compatible with a large variety of probes and cables from Metrix, BN⁴, and other manufacturers.

MX2033 3-Wire Probe Driver



Dynamic Voltage Output (mV/μm or mV/mil)
MX2033 signal output is compatible with industry-standard continuous vibration monitoring systems (including the SETPOINT⁵ Machinery Protection System) and is the format specified in API Standard 670. It uses -24Vdc excitation and provides the output signal in mV/μm, typically 7.87 mV/μm (200mV/mil).

MX2034 4-20 mA Transmitter



Static Current Output (mA/mm or mA/mil)
MX2034 signal output provides thrust, radial vibration, or shaft speed measurements directly to PLCs, DCSs, SCADA systems, or other instrumentation that accepts an ISA Standard 4-20 mA signal, without the use of a separate monitor system. The transmitter is a +24 Vdc current loop powered device. It is user-configurable to function as follows:

1. Radial vibration transmitter (4-20 mA signal is proportional to pk-pk vibration amplitude)
2. Axial position transmitter (4-20 mA signal is proportional to average probe gap)
3. Tachometer (4-20 mA signal is proportional to shaft speed).

FEATURES AND BENEFITS

Digitally Configurable

Metrix pioneered the patented technology used in the DPS which provides numerous performance and user-convenience benefits. Developed in 2005 for our vibration transmitters, the technology has proven itself in thousands of installations worldwide. You can configure the device using the included software in three ways:

- **METHOD #1** - By selecting from a discrete list of pre-configured calibration curves to standard 4140 target material and the following combinations of probe types and cable lengths:
 - Metrix MX8030 probe system, 5m and 9m lengths
 - Metrix MX2030 probe system, 5m and 9m lengths
 - Metrix / BN⁴ 7200 series 5 and 8mm probe systems, 5m and 9m lengths
 - BN⁴ 3300 / 3300XL 5 and 8mm probe systems, 5m and 9m lengths
 - **METHOD #2** - By specifying one additional factory-loaded curve¹ at time of ordering, from any of the available options for MX2033 drivers and MX2034 transmitters (refer to pages 7 and 8 respectively).
- NOTE: This memory will be left empty if not specified at time of ordering. It can be used in the field as per method #3 below.
- **METHOD #3** - Generate a custom curve in the field² by recording the gap voltage at 10 mil increments and entering it into the software. A custom linearization table is then generated and loaded into the device. This method is particularly convenient when the shaft target material composition is not known.

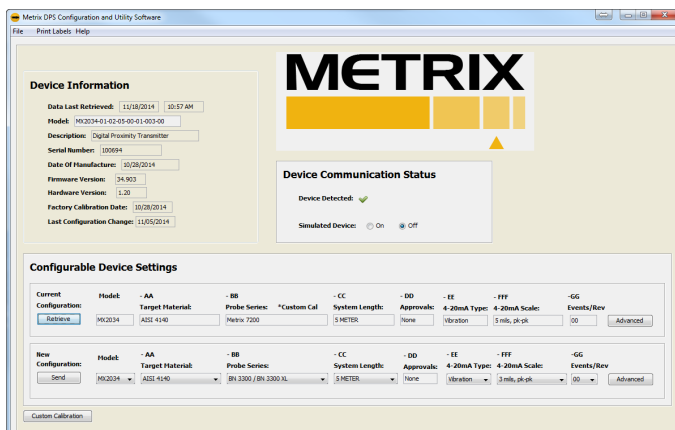

The DPS Configuration Software features a simple, intuitive user interface that makes it easy to configure the signal conditioner in the field. Users can select from a discrete list of factory pre-configured curves using drop-down boxes, or generate a custom linearization curve in the field by entering gap voltages at 10mil increments.

Configured DPS units can easily be identified in the field using the DPS configuration software and our optional Metrix User Label Kit P/N 100527 (see Accessories on page 11). The kit consists of specially shaped polycarbonate overlay labels and paper labels (Avery 6570). The customized details are printed on an Avery 6570 label, and this is affixed under a clear rectangular window in the polycarbonate overlay label, providing a weatherproof seal. Target material, probe type and series, system length, and output sensitivity can be recorded. We provide user-configurable fields where you can record installation- and device-specific details such as date of last calibration, instrument loop tag numbers, probe location (machine / bearing / angular orientation), and any other details useful to machinery and instrumentation personnel.

NOTES:

1. One additional calibration curve can be stored in the device beyond the factory standard curves of method #1. This curve can be supplied by the factory per method #2, or can be generated by the user in the field per method #3.
2. Custom curves assume standard supported probe types (MX2033/MX2034 option BB) and system lengths (MX2033/MX2034 option CC), and that mismatched systems will not be used, such a 7200 cable with an MX2030 probe. Certain material types may limit total available linear range and other specifications. These can be quantified when a material sample is provided to the factory.
3. These settings are applicable to MX2034 transmitters only.
4. Registered trademark(s) of Bently Nevada®.
5. Registered trademark(s) of Metrix®.

These configuration options provide the user with maximum flexibility and accuracy in adapting a single driver or transmitter device to the following parameters:

- Target material (including unknown or indeterminate materials)
- Probe series and tip diameters from various manufacturers
- Extension cable lengths
- Position, thrust, radial vibration or speed measurement³
- Full scale range³
- Upscale/downscale direction³

The driver or transmitter is configurable via a USB port, protected under the baseplate of the device. The DPS configuration software is available as a free download at metrixvibration.com.

FEATURES AND BENEFITS (Continued)

Full API 670 Compliance

The DPS was designed to fully comply with API 670 for linear range, interchangeability, standard probe configurations, and all other details.

Reduced Spare Parts Inventory

The DPS reduces the requirements for spare parts by allowing a single type of driver or transmitter to be field-configured for a wide range of probe types, cable lengths, and target materials.

Interchangeability

MX8030 and MX2030 probes and MX8031 and MX2031 extension cables are fully interchangeable with BN¹ 3300 and 3300XL 5mm/8mm probe systems. Such compatibility provides greater choice of suppliers without the need to replace installed probes, cables, and drivers.

Support for Older Probe Systems

Replacing a complete proximity transducer system can be not only expensive, but impractical when a machine must keep running and probes/cables are buried inside. The ability to support older probe systems is becoming increasingly important as users push their plant outage intervals to more and more years. Imagine being able to support not only a multitude of older probe systems, cable lengths, and target materials, but to be able to do so with just a single driver or transmitter. MX2033 drivers and MX2034 transmitters allow the user to change the configuration in the field for use with virtually any Metrix or BN⁴ proximity probe and cable (see ordering information on page 7 and 8 for currently supported probe systems).

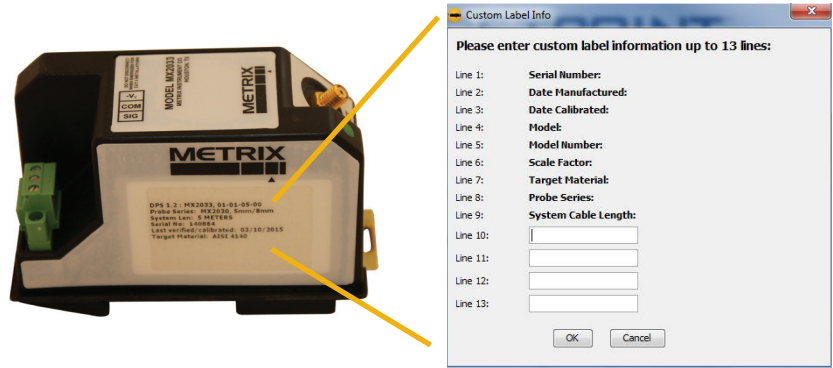

A user-generated label can be printed in the field with all device characteristics as well as user-specific tagging and installation particulars.

SPECIFICATIONS

The specifications on the following pages are based upon the following system components, target materials, gaps and temperatures^{2,3}:

- MX2033 3-wire driver
- MX8030/MX2030 8mm probe with 0.5m cable
- MX8031/MX2031 4.5m extension cable
- AISI 4140 steel target gapped at 50 mils (1.27 mm) from probe tip
- Temp = 22° C
- 17 μA_{RMS} current loop noise floor

Specifications for MX2034 loop-powered transmitters assume the same probes, cables, target materials, temperatures, and current loop noise floor as shown above.

Interchangeability and accuracy specifications assume the above Metrix products and target materials; they may differ when components from other manufacturers are mixed with Metrix components⁴.

NOTES:

1. Registered trademark(s) of Bently Nevada®.
2. The American Petroleum Institute (API) Standard 670 defines two temperature ranges for proximity probe systems: Testing Range and Operating Range. Except as otherwise noted, all specifications herein are for system performance at 22°C, in the middle of the API 670 Testing Range (0°C – 45°C).
3. Target materials other than AISI 4140 steel may restrict the transducer system’s linear range and other specifications. Consult the factory whenever using a non-4140 target to ensure the transducer system will be suitable for the intended measurement range and accuracy requirements.
4. A manufacturer’s interchangeability specifications are based on statistical variations against their own reference transducer system. Because the reference transducer systems used by other manufacturers are not within the control of Metrix, interchangeability specifications for mixed systems cannot be guaranteed, but will generally be about twice as large as when all transducer system components come from a single manufacturer. However, where known, these differences can be compensated in the field using the transducer system’s configurability capabilities, allowing mixed system performance to meet or exceed that of a non-mixed system.
5. Registered trademark(s) of Metrix Instrument Co.®

SPECIFICATIONS (Continued)

ELECTRICAL

Channels: Driver or transmitter accepts one probe and extension cable

Supported Probe Types:

MX2033 driver and MX2034 transmitters are compatible with the probes and extension cables as shown.

PROBE SERIES	TIP DIAMETER	METRIX DATASHEET
MX8030 and MX2030	5mm/8mm	1507096
Metrix and BN ¹ 3000	.190"/.300"	1004736
Metrix and BN ¹ 7200	5mm/8mm	1009553
BN ¹ 3300 and 3300XL	5mm/8mm	N/A
BN ¹ RAM and NSv	5mm	N/A

Contact factory if you need other probes or cables.

Driver or Transmitter Excitation Voltage:

(Reduced linear range will occur when voltage at the driver or transmitter terminal is more positive than -19 Vdc)

MODEL	W/O BARRIERS	W/ZENER BARRIERS	W/GALVANIC BARRIERS
MX2033	17-30 Vdc	23-26 Vdc	20-30 Vdc
MX2034			

Driver or Transmitter Max Current Consumption:

MODEL	I _{MAX}
MX2033	10 mA
MX2034	23 mA

Driver or Transmitter Output Types:

MX2033 - Terminal: 7.87 mV/μm (200 mV/mil) (instantaneous gap)

MX2034 -	TERMINAL	BNC
Radial vibration	Proportional 4-20 mA (mils pk-pk, μm)	7.87 mV/μm (200 mV/mil) (instantaneous gap)
Axial position	4-20 mA proportional to position (mils)	
RPM	4-20 mA proportional to speed	

Field Wiring Gauge:

Recommended: 0.8 mm² (18 AWG)
 Allowed: 0.2 to 1.3 mm² (16 to 24 AWG)

Field Wiring Type:

MX2033: 3-conductor shielded cable
 MX2034: 2-conductor shielded cable (4-20 mA)
 RG-58 A/U coax cable (BNC connector)

Max. Field Wiring Length:

MX2033: 1500 m (4920 ft) between driver and monitor³
 MX2034: 4-20 mA: 5000 m (16,400 ft) between transmitter and monitor³

Min. Target Size:

15.2 mm (0.6 in) diameter (assuming flat surface)

Min. Shaft Diameter:

Absolute: 50.8 mm (2.0 in)
 Recommended: 76.2 mm (3.0 in)

Linear Range:

PROBE TYPE	RANGE
MX8030 and MX2030 (5mm/8mm)	2mm or 80 mils*
BN 3300 and 3300XL (5mm/8mm)	
Metrix and BN ¹ 7200 (5mm/8mm)	1mm or 40 mils*
Metrix and BN ¹ 3000 (.190 in)	
Metrix and BN ¹ 3000 (.300 in)	1.25mm or 50 mils**
BN ¹ NSv and RAM	1.5mm or 60 mils*

* Range starts at approx. 10 mils gap (-1V)
 ** Range starts at approx. 20 mils gap (-1V)

Suggested Probe Gap:

-9V

NOTES:

1. Registered trademark(s) of Bently Nevada®.
2. Length limit is imposed by distributed cable resistance and corresponding voltage drop at maximum current output. Assumes 18 AWG 2-conductor cable with resistance of 20 Ω/km, 24 V_{dc} supply voltage, 250 Ω load resistance, no I.S. barriers. Consult the manual for further details.
3. Length limit is imposed by distributed cable capacitance and corresponding frequency response roll-off. Assumes standard 18AWG 3-conductor cable with capacitance of 290 pF/m, no I.S. barriers. Total cable capacitance in excess of 450 nF will limit frequency response at monitor to less than published 8-kHz specification. Consult the manual (Metrix Document 1093672) for further details.

Frequency Response:

MODEL	± 3dB RESPONSE	
MX2033	0-8 kHz	
MX2034	Vibration Configuration (option FF=01-49)	Position Configuration (Option FF= 0-98)
	4-20 mA: 5 Hz - 5 kHz	4-20 mA: 0 - 1.2 Hz
	Buffered: 0 - 5 kHz	Buffered: 0 - 5 kHz

4 - 20 mA Update Rate: 150 ms (applies to MX2034 only)

Incremental Scale Factor (ISF)¹⁻⁴ and Deviation from Best-Fit Straight Line (DSL):

PROBE TYPE	ISF (Incremental Scale Factor)	DSL (Deviation from Straight Line)
MX8030 and MX2030 (5mm/8mm)	7.87 mV/μm ± 5% (200 mV/mil)	± 0.025 mm (± 1 mil)
BN ⁵ 3300 and 3300XL (5mm/8mm)		
Metrix and BN ⁵ 7200 (5mm/8mm)	7.87 mV/μm ± 10% (200 mV/mil)	± 0.06 mm (± 2.4 mil)
Metrix and BN ⁵ 3000 (.190")	7.87 mV/μm ± 20% (200 mV/mil)	± 0.1 mm (± 3.9 mil)
Metrix and BN ⁵ 3000 (.300")	7.87 mV/μm ± 20% (200 mV/mil)	
BN ⁵ NSv and RAM	7.87 mV/μm ± 20% (200 mV/mil)	± 0.06 mm (± 2.4 mil)

Accuracy: 0.3% typical, 1% max.

MECHANICAL

Probe Tip Material: Polyphenylene Sulfide (PPS)
Probe Case Material: FWD-mount probe: AISI 304 stainless steel
 REV-mount probe: AISI 303 stainless steel
Probe Cable Type: 75Ω coaxial, Tefzel® 750 insulation (ethylene – tetrafluoroethylene ETFE)
Extension Cable Type: 75Ω coaxial, Tefzel® 750 insulation (ethylene – tetrafluoroethylene ETFE)
Driver Case Material: PBT thermoplastic polymer blend (contains PBT, carbon fiber, and glass beads)
Optional Flexible Armor: AISI 304 stainless steel (armor)
 AISI 303 stainless steel (armor ferrule)

Tensile Strength: Probe body to probe cable: 245N (55 lb)
 Cable to Connector: 245N (55 lb)
Connector Material: Gold-plated brass
Connector Gender: Probe: Male
 Extension Cable: Female and Male
 Driver or Transmitter: Female
Connector Type: Miniature knurled
Connector Torque: Maximum: 0.565 N-m (5 in-lb)
 Recommended: finger tight
Min. Cable Bend Radius: Without Armor: 25.4 mm (1.0 in)
 With Armor: 25.4 mm (1.0 in)

NOTE: An ETFE outer jacket is not included on Metrix extension cable and probe armor as it tends to degrade, rather than enhance, moisture and corrosion resistance.

Probe Case Torque:

PROBE TYPE	MAX. RATED	RECOMMENDED
8mm FWD mount	33.9 N-m (300 in-lb)	11.3N-m (100 in-lb)
5mm FWD mount	7.3 N-m (65 in-lb)	5.1 N-m (45 in-lb)
8mm REV mount	22.6 N-m (200 in-lb)	7.5 N-m (66 in-lb)

ENVIRONMENTAL

Operating and Storage Temperature:

Probe: -51°C to +177°C (-60°F to +350 °F)
 Extension Cable: -51°C to +177°C (-60°F to +350°F)
 Driver or Transmitter: -40°C to +85°C (-40°F to +185°F)

Relative Humidity: 95%, non-condensing

Probe tip-to-case Pressure Rating: 13.6 bar (200 psi)

Patents: Digital performance curve technology in driver and transmitter:
 US patent number 7768258.

RECOMMENDED BARRIERS











Passive Zener: MX2033: MTL 7796- (or equivalent)
 MX2034: MTL 7787+ (or equivalent)
Active Galvanic: MX2033: MTL 5531, P&F KFD2-VR4-Ex1.26, or equivalent
 MX2034: MTL 5541, P&F KFD2-STC4-Ex1, or equivalent

NOTES:

1. Values shown for 5m systems. For 9m systems, add 1.5%.
2. Includes interchangeability errors when measured in increments of 0.25 mm (10 mils) over the linear range between 0°C and 45°C (API Testing Range).
3. ISF shown assumes mV-type output and is valid for MX2033 and BNC connector on MX2034.
4. Above ISF values for MX2034 transmitter pertain only to the BNC connector. The ISF for the transmitter's 4-20mA proportional output is applicable only when configured for position measurements (EE=02). ISF is not applicable to the 4-20mA output on transmitters configured for vibration measurements (EE=01).
5. Registered trademark(s) of Bently Nevada®.

SPECIFICATIONS (continued)

HAZARDOUS AREA APPROVALS

AREA	PROBE/CABLE	DRIVER
North America	Class I, Div 1, Grps A,B,C,D -40°C to +177°C Intrinsically Safe and Non-Incendive 	Class I, Div 1, Grps A,B,C,D, T4 -40°C ≤ Ta ≤ +85°C Intrinsically Safe (MX2034) 
		Class I, Div 2, Grps A,B,C,D, T4 -40°C ≤ Ta ≤ +85°C Non-Incendive (MX2034) 
International ATEX/IECEX 	 II 1G Ex ia IIC T3 Ga -40°C ≤ Ta ≤ +177°C  II 1G Ex ia IIC T4 Ga -40°C ≤ Ta ≤ +110°C Intrinsically Safe	 II 1G Ex ia IIC T4 Ga -40°C ≤ Ta ≤ +85°C Intrinsically Safe
	 II 3G Ex nA IIC T3 Gc -40°C ≤ Ta ≤ +177°C  II 3G Ex nA IIC T4 Gc -40°C ≤ Ta ≤ +110°C Non-Incendive	 II 3G Ex nA IIC T4 Gc -40°C ≤ Ta ≤ +85°C Non-Incendive

WEIGHT AND DIMENSIONS

Dimensions: MX2033 Driver: See Fig 1, page 7
 MX2034 Transmitter: See Fig 2, page 10

Weight: Probe: 298 g (10.5 oz)
 Extension cable: - 33 g/m (0.35 oz/ft) without armor
 - 98 g/m 1.05 oz/ft) with armor
 MX2033 Driver: 247 g (8.7 oz)
 MX2034 Transmitter: 247 g (8.7 oz)

ACCESSORIES

Mounting Options for MX2033 and MX2034:

- 35mm DIN rail (standard)
- 4-hole flat base with 2" x 2" and 2.5" x 2.75" hole patterns (requires optional adapter P/N 9647)

HOW TO ORDER MX2033

MX2033-AA-BB-CC-DD (DPS 3-WIRE PROBE DRIVER)			
A	A	Material Calibration ¹	B B Probe Type
0	1	AISI-SAE 4140 CrMo Steel ¹	0 1 5mm & 8mm – MX2030/BN ³ 3300/BN ³ 3300XL
0	2	17-4 Stainless Steel ²	0 2 5mm & 8mm – Metrix 7200/BN ³ 7200
0	3	Incoloy 901	0 3 0.190" – Metrix 3000/BN ³ 3000
0	4	K500 Monel	0 4 0.300" – Metrix 3000/BN ³ 3000
0	5	Inconel 625	0 5 BN ³ NSv and RAM
0	6	410 Stainless Steel	0 8 5mm & 8mm – MX8030/BN ³ 3300/BN ³ 3300XL
0	7	316 Stainless Steel	0 9 5mm & 8mm – TightView MX8030 ¹⁰
0	8	AISI-SAE 1045 Plain Carbon Steel	9 9 Other
0	9	416 Stainless Steel	C C System Length
1	0	42CrMo4	0 5 5 meter ^{5, 10}
1	1	18CrNiMo7-6	0 7 7 meter ⁶
1	2	31CrMoV9	0 9 9 meter ^{7, 10}
1	3	ST52-3	1 5 15 feet ⁸
1	4	F6NM	2 0 20 feet ⁸
1	5	7075-T6 Aluminum	9 9 Other
1	6	Aluminized Steel	D D Approvals
1	7	AISI-SAE 1018 Steel	0 0 None
1	8	15CrNi6	0 5 Multiple Approvals ⁹
1	9	Tungsten Carbide	0 6 Custom Union Approval
2	0	304 Stainless Steel	9 9 Other
2	1	AISI-SAE 4320 Steel	
9	9	Other ⁴	

NOTES:

1. AISI-SAE 4140 chromium molybdenum steel is the standard default calibration per API 670. If no material type is specified at time of ordering, a factory-standard AISI 4140 target will be used. Calibration to target materials other than 4140 may restrict linear range and other specifications. Consult the factory.
2. Due to the electrical properties of this material, vibration measurement accuracy may be affected when using this target.
3. Registered trademark(s) of Bently Nevada®.
4. Calibration to other material types is available upon request. Metrix will normally request that the customer supply a suitable sample of the material, allowing a machined target with appropriate surface finish to be produced.
5. Compatible with BN³ 7200, 3300, 3300XL, NSv, and Metrix MX2030 probes only.
6. Compatible with BN³ NSv and RAM probes only.
7. Compatible with BN³ 7200, 3300, 3300XL, and MX2030 probes only.
8. Compatible with 3000 series probes only.
9. ETL, ATEX, Intertek and IECEx hazardous area approvals.
10. Can be used with the MX8030 Tight View Probe System.

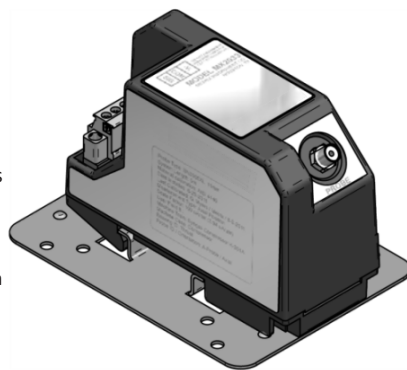
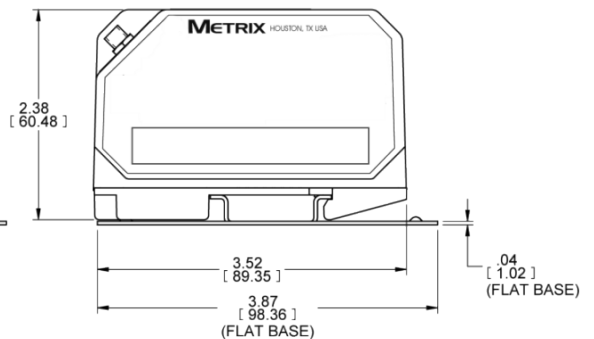
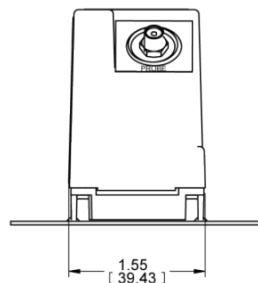
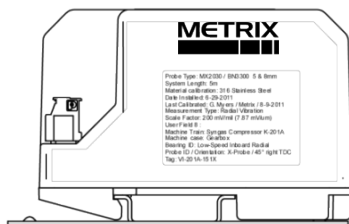
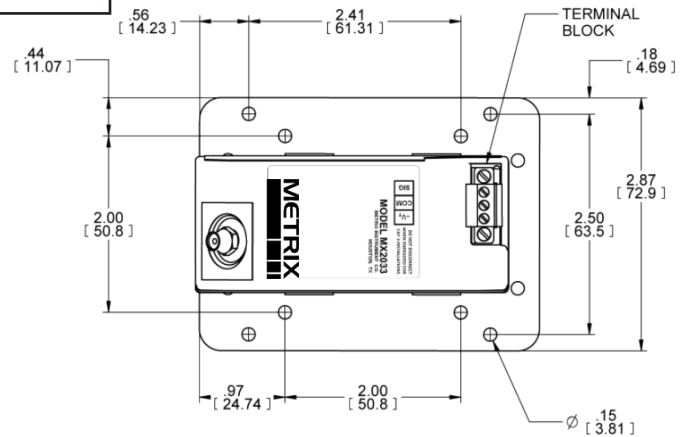

Figure 1: Dimensions in inches [mm] for the MX2033 3-wire digital proximity driver
 Note: optional 4-hole base-plate mounting adapter shown (P/N 9647). 35mm din rail mount is standard.



Dimensions are inch [mm]



HOW TO ORDER MX2034

MX2034-AA-BB-CC-DD-EE-FFF-GG (DPS 4-20 MA TRANSMITTER)																
A	A	Material Calibration¹				D	D	Approvals		F	F	F	Full Scale Range¹⁰ (Continued)			
0	1	AISI-SAE 4140 CrMo Steel ¹				0	0	None		2	0	2	2000 RPM (Speed)			
0	2	17-4 Stainless Steel ²				0	5	Multiple Approvals ⁹		3	6	2	3600 RPM (Speed)			
0	3	Incoloy 901				0	6	Custom Union Approval		4	0	2	4000 RPM (Speed)			
0	4	K500 Monel				9	9	Other		5	0	2	5000 RPM (Speed)			
0	5	Inconel 625				E	E	Measurements		6	0	2	6000 RPM (Speed)			
0	6	410 Stainless Steel				0	1	Vibration		7	5	2	7500 RPM (Speed)			
0	7	316 Stainless Steel				0	2	Position		1	0	3	10000 RPM (Speed)			
0	8	AISI-SAE 1045 Carbon Steel				0	3	Speed		1	5	3	15000 RPM (Speed)			
0	9	416 Stainless Steel								5	0	3	50000 RPM (Speed)			
1	0	42CrMo4				F	F	F	Full Scale Range¹⁰			6	0	3	60000 RPM (Speed)	
1	1	18CrNiMo7-6				0	0	1	3 mils, pk-pk (Vibration)			7	5	3	75000 RPM (Speed)	
1	2	31CrMoV9				0	0	2	4 mils, pk-pk (Vibration)			1	0	4	100000 RPM (Speed)	
1	3	ST52-3				0	0	3	5 mils, pk-pk (Vibration)			0	9	9	Other	
1	4	F6NM				0	0	4	6 mils, pk-pk (Vibration)			G	G	Pulses / Revolution		
1	5	7075-T6 Aluminum				0	0	5	10 mils, pk-pk (Vibration)			0	0	N/A (for vibration or position)		
1	6	Aluminized Steel				0	0	6	15 mils, pk-pk (Vibration)			X	X	XX= number of pulses per revolution (keyways), valid entries are two digit numbers from 01-99, with a maximum value of RPM x # Keyways ≤ 190,000		
1	7	AISI-SAE 1018 Steel				0	0	7	20 mils, pk-pk (Vibration)							
1	8	15CrNi6				0	0	8	30 mils, pk-pk (Vibration)							
1	9	Tungsten Carbide				0	0	9	40 mils, pk-pk (Vibration)							
2	0	304 Stainless Steel				0	2	1	100 µm, pk-pk (Vibration)							
2	1	AISI-SAE 4320 Steel				0	2	2	150 µm, pk-pk (Vibration)							
9	9	Other ³				0	2	3	200 µm, pk-pk (Vibration)							
B	B	Probe Type				0	2	4	250 µm, pk-pk (Vibration)							
0	1	5mm & 8mm – Metrix MX2030/BN ⁴ 3300/BN3300XL				0	2	5	300 µm, pk-pk (Vibration)							
0	2	5mm & 8mm – Metrix 7200/BN ⁴ 7200				0	2	6	400 µm, pk-pk (Vibration)							
0	3	0.190" – Metrix 3000/BN ⁴ 3000				0	2	7	500 µm, pk-pk (Vibration)							
0	4	0.300" – Metrix 3000/BN ⁴ 3000				0	2	8	750 µm, pk-pk (Vibration)							
0	5	BN ⁴ NSv and RAM				0	2	9	1000 µm, pk-pk (Vibration)							
0	8	5mm & 8mm – MX8030/BN ⁴ 3300/BN3300XL				0	5	0	30-70 mils, avg gap (Position)							
0	9	5mm & 8mm – TightView MX8030 ¹¹				0	5	1	20-80 mils, avg gap (Position)							
9	9	Other				0	5	2	10-90 mils, avg gap (Position)							
C	C	System Length				0	5	3	10-50 mils, avg gap (Position)							
0	5	5 meter ^{5,11}				0	5	4	20-70 mils, avg gap (Position)							
0	7	7 meter ⁶				0	5	5	10-60 mils, avg gap (Position)							
0	9	9 meter ^{7,11}				0	7	0	750-1750 µm, avg gap (Position)							
1	5	15 feet ⁸				0	7	1	500-2000 µm, avg gap (Position)							
2	0	20 feet ⁸				0	7	2	250-2250 µm, avg gap (Position)							
9	9	Other				0	7	3	250-1250 µm, avg gap (Position)							
					0	7	4	500-1750 µm, avg gap (Position)								
					0	7	5	250-1500 µm, avg gap (Position)								

- NOTES:**
- AISI-SAE 4140 chromium molybdenum steel is the standard default calibration per API Standard 670. If no material type is specified at time of ordering, a factory-standard AISI 4140 target will be used. Calibration to target materials other than 4140 may restrict linear range and other specifications; consult the factory.
 - Due to the electrical properties of this material, vibration measurement accuracy may be affected when using this target.
 - Calibration to other material types is available upon request. Metrix will normally request that the customer supply a suitable sample of the material, allowing production of a machined target with appropriate surface finish.
 - Registered trademark(s) of Bently Nevada®.
 - Compatible with 7200, 3300, 3300XL, NSv, and MX2030 probes only.
 - Compatible with NSv and RAM probes only.
 - Compatible with 7200, 3300, 3300XL, and MX2030 probes only.
 - Compatible with 3000 series probes only.
 - ETL, ATEX, Intertek and IECEx hazardous area approvals.
 - Refer to Table 1 on following page for probe (BB), measurement (EE), and full scale range (FFF) compatibility details.
 - Can be used with the MX8030 Tight View Probe System.

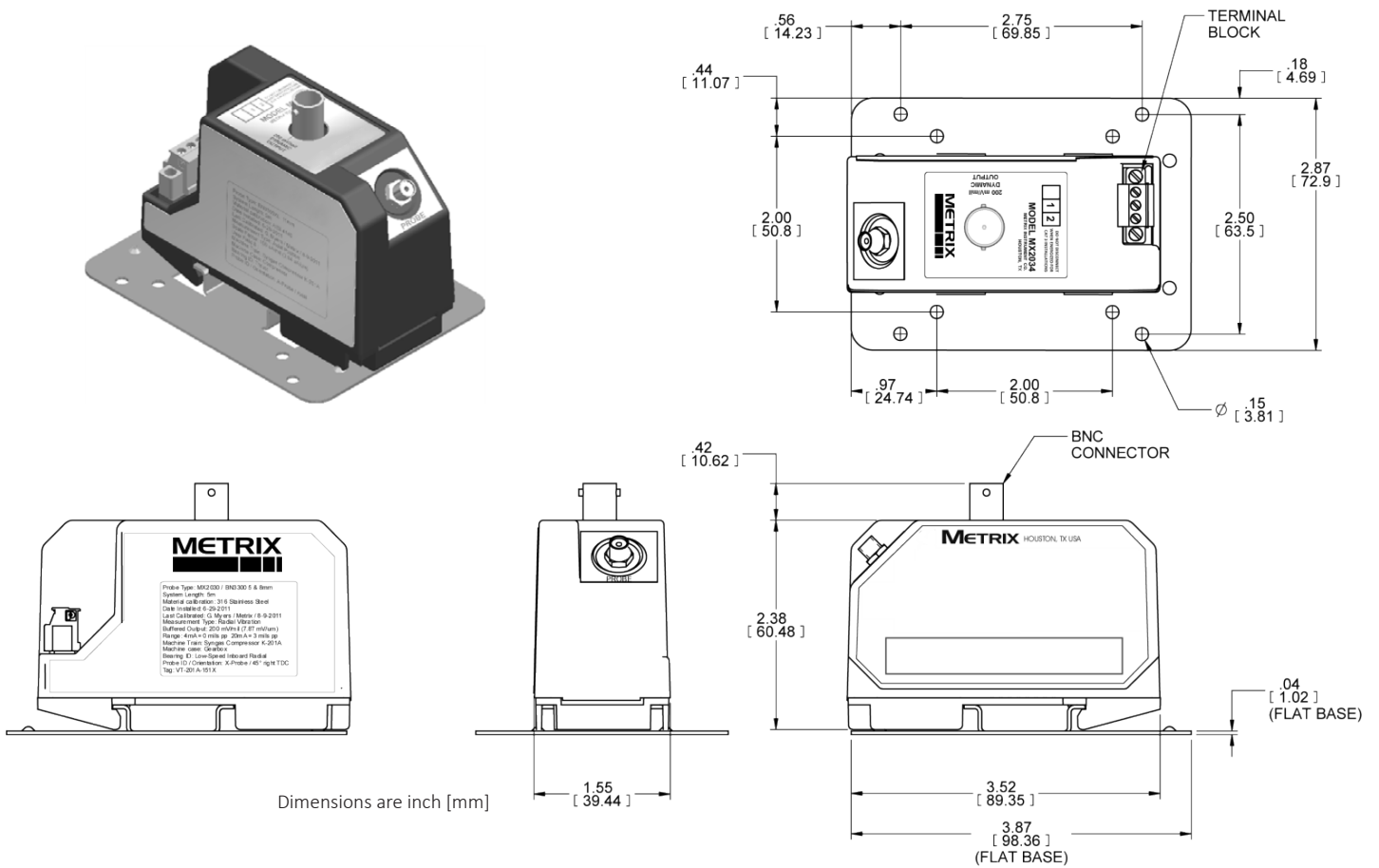

**Table 1 - MX2034 Compatibility
Probe Type vs. Measurement Range**

* Registered trademark(s) of Bently Nevada®.

Measurement Type	Full Scale Range	5mm & 8mm MX8030/MX2030/ BN* 3300/BN* 3300XL 5mm & 8mm Metrix 7200/ 0.190" Metrix 3000/ BN* 3000 0.300" Metrix 3000/ BN* 3000 NSv* & RAM BN*				
		BB=01	BB=02	BB=03	BB=04	BB=05
EE=01 (Vibration)	FFF=001 3 mils, pk-pk	YES	YES	YES	YES	YES
	FFF=002 4 mils, pk-pk					
	FFF=003 5 mils, pk-pk					
	FFF=004 6 mils, pk-pk					
	FFF=005 10 mils, pk-pk					
	FFF=006 15 mils, pk-pk					
	FFF=007 20 mils, pk-pk					
	FFF=008 30 mils, pk-pk					
	FFF=009 40 mils, pk-pk					
	FFF=021 100 μm, pk-pk					
	FFF=022 150 μm, pk-pk					
	FFF=023 200 μm, pk-pk					
	FFF=024 250 μm, pk-pk					
	FFF=025 300 μm, pk-pk					
	FFF=026 400 μm, pk-pk					
FFF=027 500 μm, pk-pk						
FFF=028 750 μm, pk-pk						
FFF=029 1000 μm, pk-pk						
EE=02 (Position)	FFF=050 30-70 mils, avg gap	YES	YES	NO	YES	YES
	FFF=051 20-80 mils, avg gap			NO	NO	NO
	FFF=052 10-90 mils, avg gap			YES	YES	YES
	FFF=053 10-50 mils, avg gap			NO	YES	NO
	FFF=054 20-70 mils, avg gap			YES	YES	YES
	FFF=055 10-60 mils, avg gap			NO	YES	YES
EE=02 (Position)	FFF=070 750-1750 μm, avg gap	YES	YES	NO	YES	NO
	FFF=071 500-2000 μm, avg gap			NO	NO	NO
	FFF=072 250-2250 μm, avg gap			YES	YES	YES
	FFF=073 250-1250 μm, avg gap			NO	YES	NO
	FFF=074 500-1750 μm, avg gap			YES	YES	YES
	FFF=075 250-1500 μm, avg gap			NO	YES	YES
EE = 03 (Speed)	FFF=202 2000 RPM	YES	YES	YES	YES	YES
	FFF=362 3600 RPM					
	FFF=402 4000 RPM					
	FFF=502 5000 RPM					
	FFF=602 6000 RPM					
	FFF=752 7500 RPM					
	FFF=103 10000 RPM					
	FFF=153 15000 RPM					
	FFF=503 50000 RPM					
	FFF=603 60000 RPM					
	FFF=753 75000 RPM					
	FFF=104 100000 RPM					

Figure 2: Dimensions in inches [mm] for MX2034 digital proximity transmitter
 Note: optional 4-hole baseplate mounting adapter shown (P/N 9647). 35mm din rail mount is standard.



ACCESSORIES

DPS User Label Kit for up to 16 devices (P/N 100527)

Each MX2033 driver and MX2034 transmitter comes with the four factory-applied labels summarized below. The *DPS User Label Kit* allows the Left Sidewall Label to be replaced with a customized label containing installation-specific data, as depicted on page 3 of this datasheet. The User Label Kit contains enough materials for labeling up to 16 signal conditioners as follows:

- 16 specially-shaped polycarbonate adhesive labels with a clear rectangular window and the Metrix logo.
- A sheet of 32 standard 1.75" W x 1.25" H labels (Avery 6570).

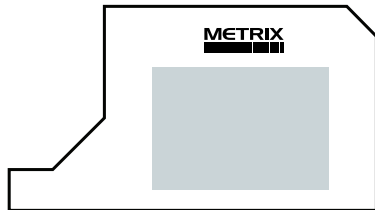

Using the Metrix DPS Configuration Software, the desired information is printed directly onto the Avery 6570 sheet using any Windows-compatible inkjet or laser printer. The printed Avery label is removed from the sheet, placed behind the window on the polycarbonate label, and both are then affixed to the left sidewall of the DPS signal conditioner. The polycarbonate label uses the same finish as all other factory-applied labels, providing protection from the elements and giving a clean, durable, and professional finish.

NOTE: The User Label Kit must be ordered separately and is not automatically included with driver or transmitter.

Of the four labels affixed to each DPS signal conditioner, only the Left Sidewall Label is intended for customization and field replacement. The others are designed to remain permanently affixed to the device during its life and contain information that does not change with device configuration.

1. Left Sidewall Label (*Configured Devices*)

All devices ordered in a programmed state will have this label a fixed. The label will reflect the as-ordered configuration data.

2. Right Sidewall Label

This is a factory-applied permanent label with the serial number, date of manufacture, model number and all approvals data.

3. Front Label

This is a factory-applied permanent label that indicates the connector for the probe and extension cable.

4. Top Label

This is a factory-applied permanent label that indicates the wiring terminals, model number, and (MX2034 only) BNC connection details.

* Registered trademark(s) of Bently Nevada®.

DIN to 4-Hole Flat Base Mounting Adapter (P/N 9647)

This adapter allows the 35mm DIN rail clip on MX2033 driver, and MX2034 transmitters to be compatible with a 4-hole flat base mounting method. The adapter has industry-standard hole patterns for both a 2" x 2" square and a 2.75" x 2.5" rectangle. The 2" x 2" pattern matches the holes on Metrix 5533 drivers and BN* 3300, 7200, and 3000 series Proximito* devices. The 2.75" x 2.5" pattern matches the holes on Metrix 5465/5488 transmitters and BN* 990/991 transmitters. Material is 19 gauge mild steel (ASTM A366 or equal) with gold chromate zinc plating.

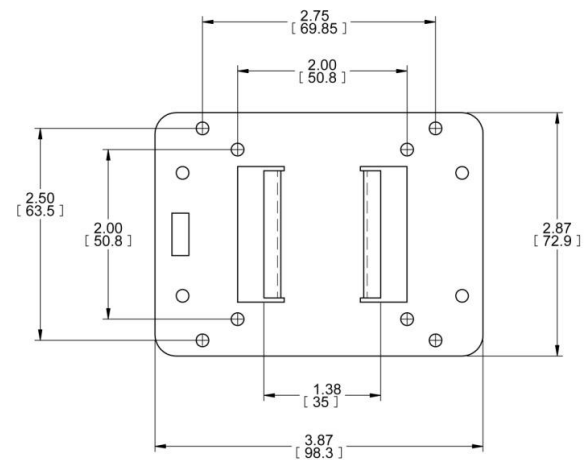
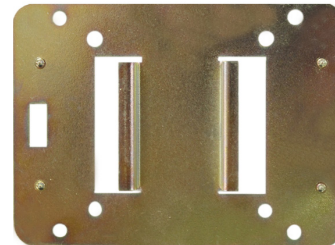

Dimensions are inch [mm]

MANUALS AND SOFTWARE

The most recent versions of the Metrix DPS Configuration Software and the DPS user manual can be downloaded from the Metrix website, www.metrixvibration.com.

NOTE: Manuals are published electronically in Adobe® PDF format and may be printed and freely distributed. Adobe Reader is required and can be downloaded free from www.adobe.com.