

## DIFFERENTIAL DC CURRENT RELAY DC Earth Leakage Relay Type: DDCA

### FEATURES

- Early warning for Insulation deterioration and Earth leakage
- Minimum current detection
- 6 Ranges from 5 to 200mA selected by DIP switches
- Wide DC supply range from 18 to 340 V
- Directional 12 ± 8mA output and LED indication for supervision and easy trouble shooting
- External current transformer Ø50mm or Ø90mm
- Extremely compact and  $\mu$  metal screened transformer for high accuracy and noise immunity
- Time delay - on and off - individually adjustable
- Relay function can be inverted
- Latch function can be selected
- LEDs indicate the status of the relay, latch and timing function
- Test and Reset switch

### FUNCTION DIAGRAM

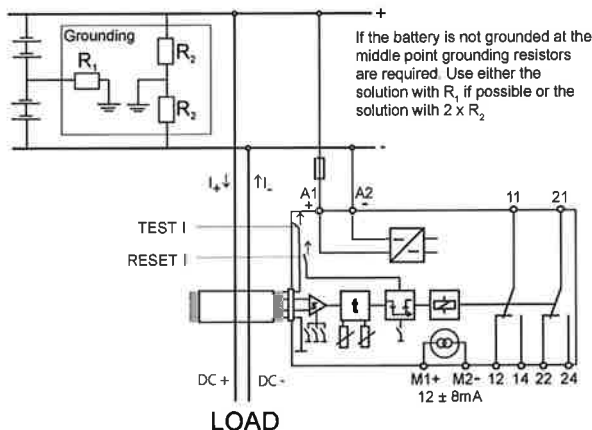
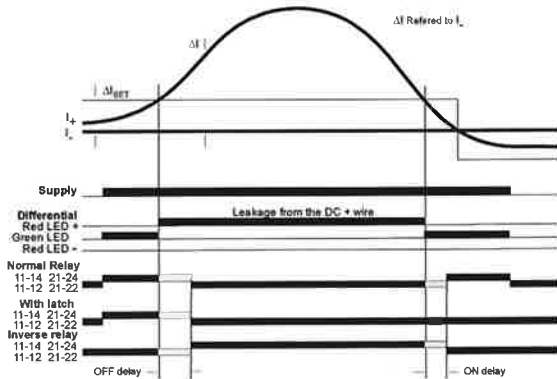

### Description:

The differential DC current relay is designed to monitor IT systems for insulation deterioration. The DDCA is able to selectively indicate faults in branched systems. In addition to this it shows if the fault is related to the positive or the negative wire for easy maintenance. Used with only one wire through the sensing core, it can monitor a circuit for connectivity and function. If the DC current drops below the set value, the relay will trip. This is another key feature as the DDCA allows, up to the cable capacity, AC and DC Amps to flow under normal conditions without having the usual voltage drop and heat from a shunt resistor.

### Operation:

Set the DIP switches (123) to the requested sensitivity, latching relay (5) to On or Off and the relay (6) to Normal (fail safe) or Inverse function. When the power is connected to A1 and A2, and with no differential current through the sensing coil, the green LEDs for Differential and Relay ON (normal function) will be on. When a differential current above the set limit is detected, one of the red Differential LED's will be switched on, showing the polarity of the cable leaking to ground. (For leak currents above 15A both red Differential LEDs will be switched on indicating that the DDCA is saturated and cannot detect which cable is leaking). When high current is detected, the OFF delay starts to elapse, indicated by a green LED, and the relay will drop out when the set time has expired. If the latch function is selected the relay will stay de-energized (normal function) and the red Latch LED will be on until the Reset button is activated. If the latch function is not active and the differential current drops below the set level, the green Differential LED will be switched on and the ON delay starts to elapse, indicated by a green LED. The relay will pull in (normal function) when the set time has expired.

### Test and Reset function:

The Test switch activates a real functional test as it conducts a DC current through a separate winding on the sensing core. The Reset switch will while activated release the latch function.

### Application:

Selective DC earth leakage detection in single and branched systems. The DDCA is the solution for pure DC installations used in UPS and control systems for chemical, petrochemical, mining industry as well as seagoing vessels. The DDCA is also ideal in AC installations including loads with rectifiers e.g. in variable speed drives, causing the AC monitors to malfunction.

### PROGRAMMABLE FEATURES

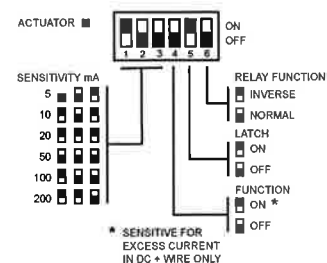

## SPECIFICATIONS

### INPUT

Set points selectable by dipswitch  
Differential  
Transformer Diameter

AC/DC Current. No specified limitation  
5, 10, 20, 50, 100, 200mA

Typical 2%  
Ø 50mm  
Ø 90mm

### PERFORMANCE PARAMETERS

#### TIMING

Response time  
Time range during run

Typical <200msec.  
Separate On and Off delay  
0 - 10 sec, adjustable

#### ELECTRICAL

Current direction indication  
Precision  
Temp. dependence

Up to 15 Amp  
Set point ± 2%  
Analog output class 2  
Typ. ± 0.02 % / °C

### OUTPUT

#### RELAY

Contact rating

Mechanical life

#### ANALOG INDICATION

Current

2 C/O, AgNi/Au  
6 A, 250 VAC, 1500 W  
See figure for DC rating  
30 million operations

12mA @ Input (fault) = 0mA  
12 ± 8mA @ input = ± set point current

### SUPPLY

Supply range  
Power consumption

DC voltage  
18 - 340V  
Max 3 W

### GENERAL

Precaution

The DDCA is screened with µ metal for high immunity. If the analog output in the highly sensitive ranges is used, precautions should be taken against permanent magnetic fields close to the DDCA as they can influence on the accuracy. In the sensitive ranges the wires should be kept close and in the center of the core.

Temperature range  
Humidity  
Dielectric test voltage

- 25 °C to + 55 °C ambient  
Up to 90 % RH non-condensing  
Coil to relay contacts 4000 VAC  
Pole to pole 2500 VAC  
Size 3: 0.17 kg, Size 5: 0.23 kg

Weight



Directive 2002/95/EC of  
EMC directive 89/336:

International Standards  
RoHS  
EN50081 - Emission  
EN50082 - Immunity  
EN60255 - Electrical Relays

Low voltage directive 73/23:

## ORDERING INFORMATION

### Main Unit DDCA

TYPE  
Differential DC current control relay

SUPPLY VOLTAGE  
18 V - 340 VDC

ADJUSTMENT  
Dipswitch adj.

HOUSING  
Rail mounting

SIZE  
35 mm  
55 mm

CODE END

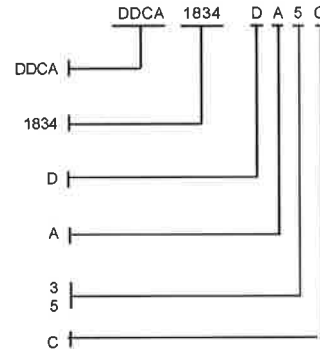

### EXTERNAL COIL DDCC

TYPE  
External Coil DDCC

Coil Size, Ø Inside/Outside

Length, connecting cable, cm

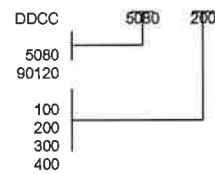

### RELAY CONTACTS

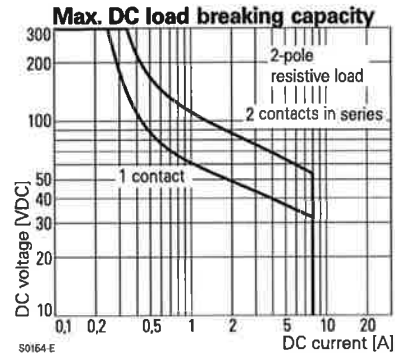

### Calculations of grounding resistors for not grounded batteries

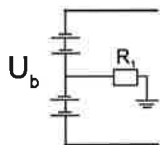

$$R_1^* = \text{Max} \frac{U_b}{4 \Delta I_{\text{set}}} \Omega$$

$$\text{Size of resistor } W^{**} = \text{Min. } 0,4 \frac{U_b^2}{R_1} \text{ Watt}$$

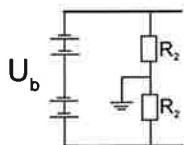

$$R_2^* = \text{Max} \frac{U_b}{2 \Delta I_{\text{set}}} \Omega$$

$$\text{Size of resistor } W^{**} = \text{Min. } 1,6 \frac{U_b^2}{R_2} \text{ Watt}$$

### Examples for $U_b = 48V, \Delta I_{\text{set}} = 5mA$

$$R_1 = \text{Max} \frac{48}{4 \times 0,005} = \text{Max. } 2400 \Omega$$

$$W = \text{Min. } 0,4 \frac{48^2}{2400} = \text{Min. } 0,384 \text{ Watt}$$

$$R_2 = \text{Max} \frac{48}{2 \times 0,005} = \text{Max. } 4800 \Omega$$

$$W = \text{Min. } 1,6 \frac{48^2}{4800} = \text{Min. } 0,768 \text{ Watt}$$

\* The calculation of the resistor is based on a safety factor of 2 corresponding to a detection of a short from one pole to ground down to half battery voltage. A resistor selected according to the maximum resistor value as calculated above will limit the leak current to 2 times  $\Delta I_{\text{set}}$  in case of direct short to ground. If it is a branched circuit with distributed "acceptable" leaks, it is recommended to use a lower value of the resistor.

\*\*The calculation of the resistor size is based on a safety factor of 1,6 corresponding to an acceptable increase in battery voltage of up to 26%.