

# 6721/6722 Vacuum Switch

# herga

Technology Ltd

- Switches have been designed primarily for the OEM manufacturer who requires high reliability
- UL approved versions available
- Double pole switching available as 6722
- Wide choice of microswitch options including tag configurations
- High performance repeatability



## Reference dimensions

5 fixing holes , 4.5 mm deep to suit No. 4 self tapping screws on 28.5 PCD

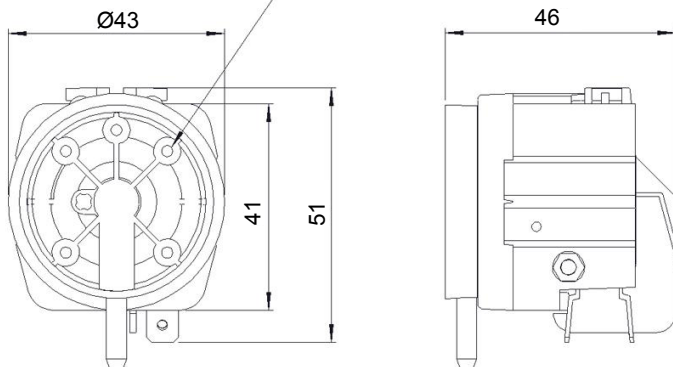

## 6721 - Range options and specifications

		Stock model				
Model part no.		6721-40	6721-03	6721-06	6721-20	6721-30
Vacuum range min.	mbar	185	7.5	17.5	32	70
Vacuum range max.	mbar	670	20	37	80	200
Body withstand pressure	mbar	2550				
Connecting tube reference		2311-01 / 2311-08 to suit Ø4 mm spout				
Diaphragm		Neoprene				
Mechanical life	Cycles	1 x 10 <sup>6</sup>	2 x 10 <sup>6</sup>	1 x 10 <sup>6</sup>	1 x 10 <sup>6</sup>	1 x 10 <sup>6</sup>
Spring		Spring steel fitted in vacuum cavity, therefore in contact with media				

## 6721 - Electrical data

Model	6721-03			6721-06			6721-20/30/40			
Contact configuration	SPCO									
Contact plating	Silver									
Electical life	Cycles	2 x 10 <sup>6</sup> @ 1A			2 x 10 <sup>6</sup> @ 6A 5 x 10 <sup>4</sup> @ 10A			2 x 10 <sup>6</sup> @ 10A 1 x 10 <sup>4</sup> @ 21A		
Maximum electrical load										
	Voltage	Resistive	Inductive	Resistive	Inductive	Motor (Pf0.75)	Resistive	Inductive	Motor (Pf0.75)	
	125V	3A	1A	10A	3A	0,5HP	21A	15A	1HP	
AC	250V	3A	1A	10A	3A	0,5HP	21A	15A	2HP	
DC	6V	3A	1A	10A	3A		21A	21A		
	12V	3A	1A	5A	3A		15A	15A		
	24V	1A	0,5A	5A	3A		8A	7A		
	60V	1A	0,5A	1A	0,5A		1A	0,5A		
	110V	0,5A	0,2A	0,5A	0,2A		0,5A	0,2A		
	220V	0,25A	0,1A	0,25A	0,1A		0,25A	0,1A		

## General specifications

Standards/approvals	UL 508 specific models only	Pressure range	See ordering information
Degree of protection	n/a	Operating temperature range	-5°C to +70°C
Connection method	Back & side entry spout, Ø4 mm or 1/8" BSPT & NPT brass	Body material	Thermoplastic
Electrical rating	See table	Weight	0.04 kg
Contact configuration	See table	Additional information	Setting accuracy +/- 10% For very low power circuits, gold contact versions are available on request Alternative diaphragm and spring materials available on request

## Suitability for use with the following media:

Acetone	☑	Glycol	✓
Ammonia (Liquid)	☑	Hydraulic Oil	✓
Amyl Alcohol to 20°C	☑	Hydrogen	✓
Automotive Brake Fluid	☑	Lubricating Oil	✓
Beer	☑	Milk	☑
Benzyl Alcohol	x	Mineral Oil	✓
Butane	✓	Natural Gas	✓
Carbon Dioxide – Dry	✓	Nitric Acid (Dil.)	x
Citric Acid	✓	Oxygen to 70°C	✓
Copper Sulphate (Sol.)	☑	Petrol	✓
Compressed Air	✓	Plating Solution (Chrome)	☑
Cutting Oil	✓	Salt Water	☑
Diesel Oil	✓	Sewage	✓
Detergent Solution	✓	Sulphur Dioxide	x
Fuel Oil	✓	Turpentine	✓
		Vinegar	☑
		Water	✓

- ✓ = Recommend
- ☑ = Suitable with modification
- x = Not suitable

## 6721: Mounting plate details

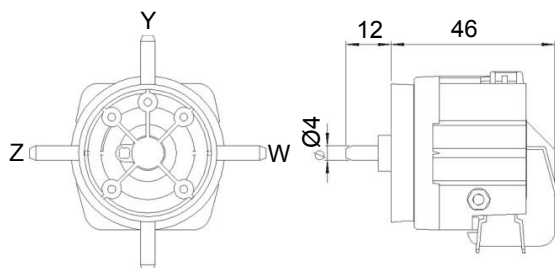

Non-standard tube connection positions for Ø4 spout

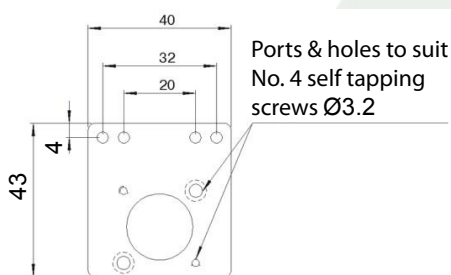

Mounting plate & 2 screws  
6050-6000-0001