

Tipo Type	F	G	H -0.5	I	L	M	Q	V	W	Z	X	Y	Peso Weight (Kg)
RBS 15	200	191	112	34	391	50	222	252	24	50	8	27	36
RBS 25	218	208	112	34	426	65	222	252	24	50	8	27	41
RBS 35	243	265	160	42.5	509	80	318	295	38	80	10	41	85
RBS 45	268	295	160	42.5	569	80	318	295	38	80	10	41	97
RBS 46	301	345	160	42.5	669	100	318	295	38	80	10	41	117
RBS 55	309	330	184	53.5	639	100	368	345	48	110	14	51.5	141
RBS 65	340	361	184	53.5	701	150	368	345	48	110	14	51.5	157
RBS 66	396	417	184	53.5	813	150	368	345	48	110	14	51.5	190
RBS 75	345	365	224	67.5	710	150	448	415	55	110	16	59	206
RBS 85	405	423	224	67.5	828	150	448	415	55	110	16	59	246
RBS 86	460	478	224	67.5	938	200	448	415	55	110	16	59	312
RBS 95	415	449	264	84	864	150	528	522	60	140	18	64	354
RBS 105	463	497	264	84	960	200	528	522	60	140	18	64	494
RBS 106	538	572	264	84	1110	200	528	522	60	140	18	64	434
RBS 115	473	513	299	106	986	200	598	618	70	140	20	74.5	532
RBS 125	528	568	299	106	1096	250	598	618	70	140	20	74.5	597
RBS 126	628	668	299	106	1296	250	598	618	70	140	20	74.5	662
RBS 126	628	668	299	106	1296	300	598	618	70	140	20	74.5	662
RBS 135	538	592	359	135	1130	250	718	790	85	170	22	90	900
RBS 145	641	695	359	135	1336	300	718	790	85	170	22	90	1030
RBS 155	716	770	359	135	1486	300	718	790	85	170	22	90	1170

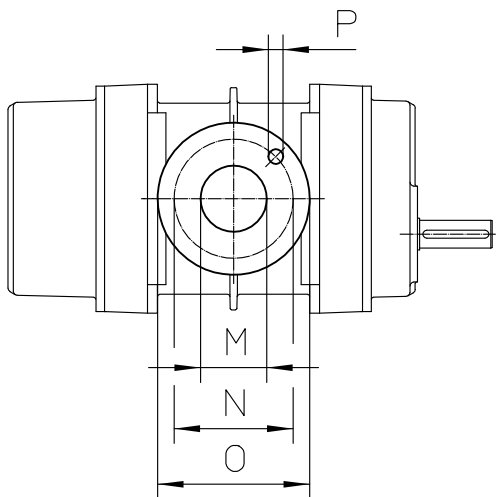

Foratura flange piane PN10 UNI EN 1092-2 o ANSI 125 FF
Drilling for flat flanges UNI EN 1092-2 NP10 or ANSI 125 FF

M UNI PN10 DN	N	O	P	N. FORI Holes	M ANSI 125 FF inch	N	O	P	N. FORI Holes
50	125	165	18	4	2"	120.6	165	18	4
65	145	185	18	4	2½"	139.7	185	18	4
80	160	200	18	4	3"	152.4	200	18	4
100	180	230	18	8	4"	190.5	230	18	8
125	214	255	22	8	5"	214	255	22	8
150	240.2	285	23	8	6"	240.2	285	23	8
200	296	340	23	8	8"	296	340	23	8
250	350	405	24	12	10"	362	405	24	12
300	400	475	24	12	12"	431.8	475	24	12

Salvo modifiche tecniche / we reserve the right to modify technical data